

- Smallest triangulation sensor on the market
- Probe diameter - from 9 mm
- Measured inner diameter - from 10 mm
- Accuracy - from  $\pm 3\mu\text{m}$
- Sampling rate - up to 9,4 kHz
- Probes with BLUE laser to control reflecting and semitransparent objects
- Probes with in-built slip ring

Contactless measurement of inner diameter, ovality, coaxiality, cylindricity and shape of holes, tubes, hosepipes, bushes, gun barrels, etc.

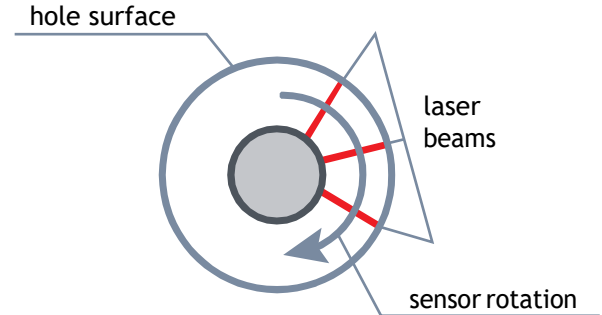

The probe is inserted into the hole and probe or sample is driven in rotation. Laser triangulation sensor built in the probe measures the distance to the hole wall synchronously with the rotation angle. The set of the polar surface coordinates allows to calculate the required parameters. Additional linear translation allows to build 3D model of the hole.



Parameter	ZLDS104 (609Rt)-10-19	ZLDS104 (609Rt)-18-45
Measured diameters, mm	9.2...19	16...48
Laser sensor linearity	$\pm 0.05\% \text{FS}$	$\pm 0.05\% \text{FS}$
Sensor measurement frequency, Hz	9400	
Rotational speed for Rt version, no more rps	4	
Laser safety Class	2 (IEC60825-1)	
Interface	RS232 or RS485 or Ethernet	
Synchronization input: trigger, A-B encoder, V	2,4-24	
Minimal distance to the hole bottom, mm	20	
Hole depth, mm	by request	
Power supply, V	9...36	
Power consumption, W	1,5-2	

\* for other measured diameters and hole depth ranges please consult factory

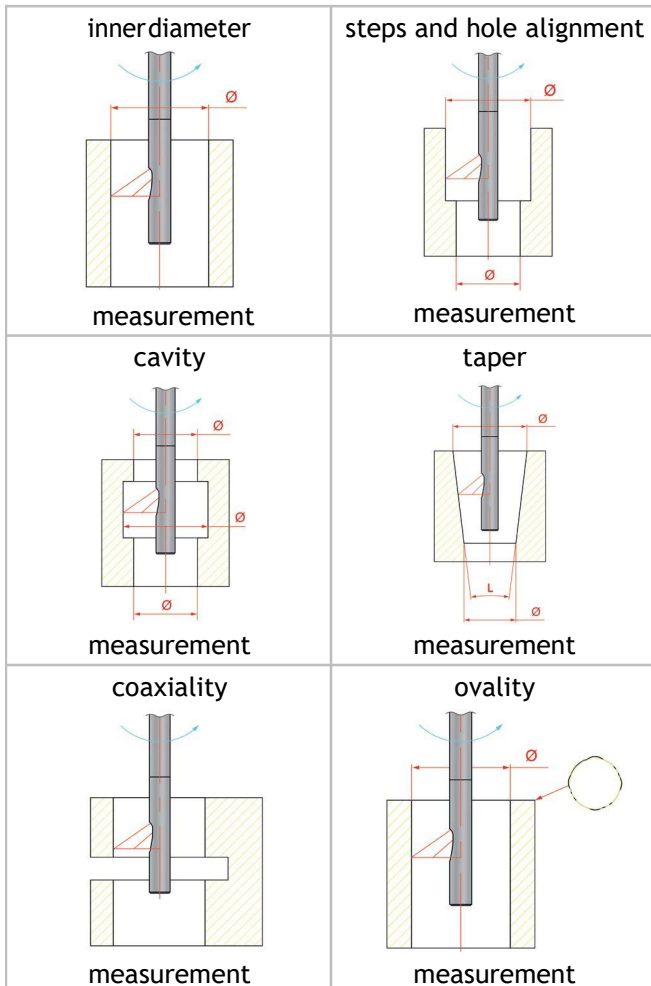

### ZLDS104-9-19/ZLDS104-16-48

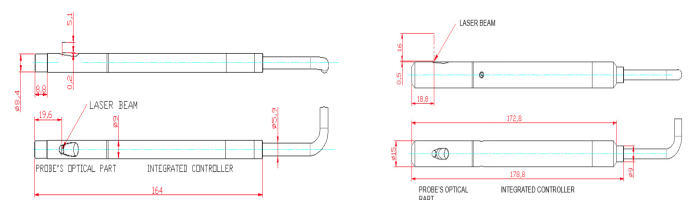

### ZLDS104Rt-9-19/ZLDS104Rt-16-48

